

1001

ETANCHE SR

Foyer 15kW



FP-CP-0002-04

Foyer étanche sans relevage

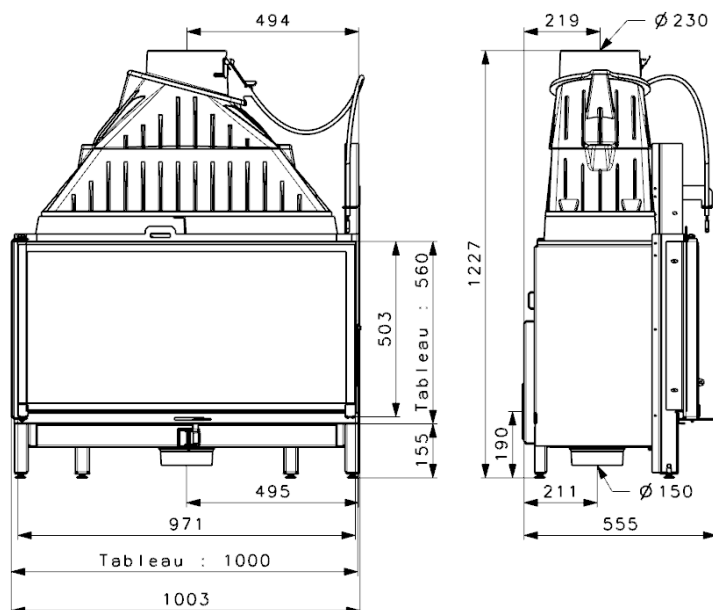

GAMME BOIS



FABRICATION FRANÇAISE



Le label du chauffage au bois



Caractéristiques:

- ▶ Puissance: 15,2kW
- ▶ Bûche 50cm
- ▶ Rendement nominal: 78,9%
- ▶ Rendement saisonnier: 68,9%
- ▶ Co : 0,05%
- ▶ Particules : 32mg/Nm3
- ▶ Cov : 28,9mg/Nm3
- ▶ Nox : 93,3mg/Nm3
- ▶ Niveau : A
- ▶ EEI : 105
- ▶ Indice I' : 0,3
- ▶ NF EN 13229
- ▶ Arrivée d'air : $\varnothing 150$
- ▶ Sortie : dessus $\varnothing 230$

Principaux avantages :

- ▶ Combustion haute performance
- ▶ Grande vision du feu
- ▶ Fabrication Française
- ▶ Intérieur fonte
- ▶ Flamme verte 7*
- ▶ Étanche RT 2012
- ▶ Double combustion
- ▶ Cadre en option

Signe votre confort depuis 1961

