

1002-2V-2

ETANCHE SR
Foyer 16kW



FP-CP-0005-03

Foyer étanche porte sans relevable

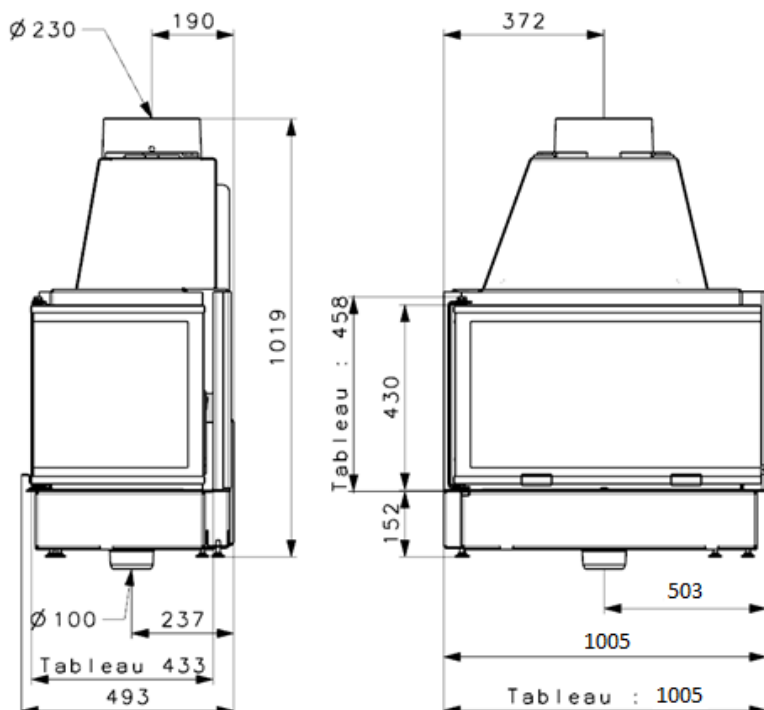

GAMME BOIS



Caractéristiques:

- ▶ Puissance: 16,5kW
- ▶ Bûche 50cm
- ▶ Rendement nominal : 75,38%
- ▶ Rendement saisonnier : 65,38%
- ▶ Co : 0,06%
- ▶ Particules : 28mg/Nm3
- ▶ Cov : 38,25mg/Nm3
- ▶ Nox : 120,87mg/Nm3
- ▶ Niveau : A
- ▶ EEI : 100
- ▶ Indice I' : 0,4
- ▶ NF EN 13229
- ▶ Arrivée d'air : Ø 100
- ▶ Sortie : dessus Ø 230

Principaux avantages :

- ▶ Combustion haute performance
- ▶ Grande vision du feu
- ▶ Fabrication Française
- ▶ Flamme verte 7*
- ▶ Ecodesign
- ▶ Étanche RT 2012
- ▶ Double combustion
- ▶ Cadre en option
- ▶ 2 Vitres

Coloris



Signe votre confort
depuis 1961

FABRICATION
FRANÇAISE

