

1001-DF-2-PR/SR

Étanche
Insert 18kW



FP-CP-0055-01

Insert intérieur fonte étanche 1 porte relevable + 1 sans relevage



TABLEAU 1000x560



GAMME BOIS

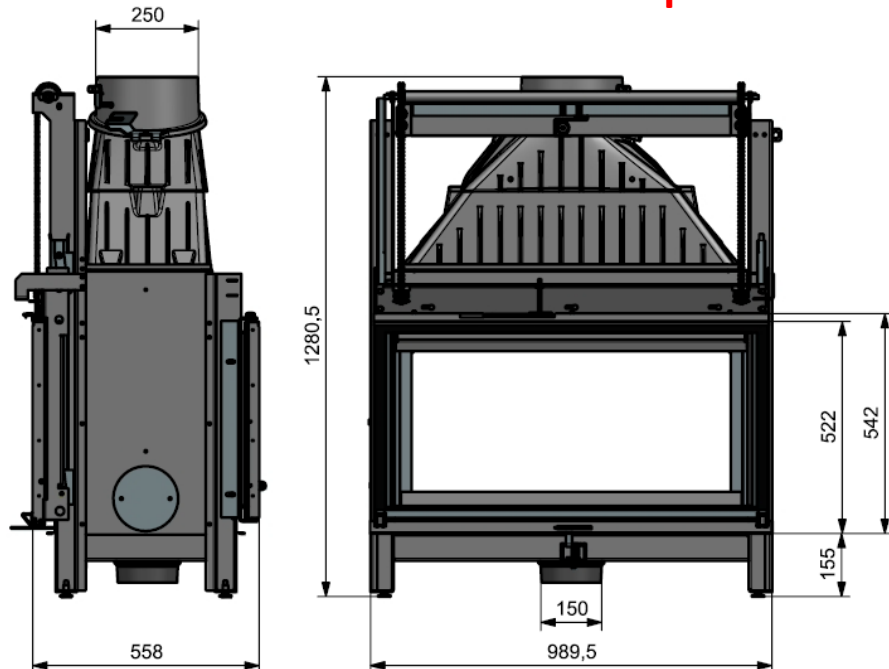

FABRICATION
FRANÇAISE



flamme
VERTE

Le label
du chauffage
au bois

7★

Caractéristiques:

- ▶ Puissance: 18kW
- ▶ Bûche 50cm
- ▶ Rendement nominal : 77,8%
- ▶ Rendement saisonnier : 67,8%
- ▶ Co : 0,089%
- ▶ Particules : 37mg/Nm3
- ▶ Cov : 72mg/Nm3
- ▶ Nox : 111mg/Nm3
- ▶ Niveau : A
- ▶ EEI : 103
- ▶ Indice I' : 0,5
- ▶ NF EN 13229
- ▶ Poids : 265kg
- ▶ Arrivée d'air : Ø 150
- ▶ Sortie : dessus ou arrière Ø 250

Avantages:

- ▶ Double face
- ▶ Grande vision du feu
- ▶ Intérieur fonte
- ▶ Combustion haute performance
- ▶ Fabrication Française
- ▶ Flamme verte 7*
- ▶ Ecodesign
- ▶ Étanche RT 2012
- ▶ Double combustion
- ▶ porte relevable d'un coté
- ▶ Biofiltre

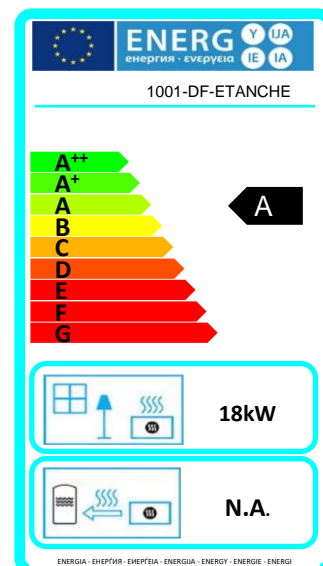

Signe votre confort
depuis 1967