

BREVAL

Poêle à bois 9kW



FP-CP-0574-04

Poêle sur pieds

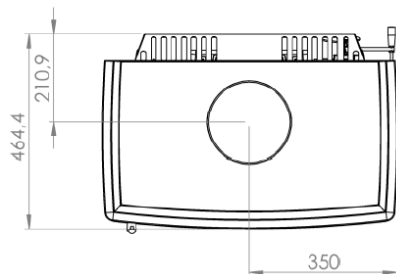
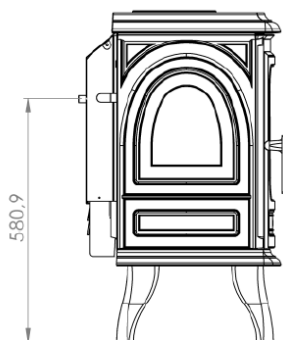
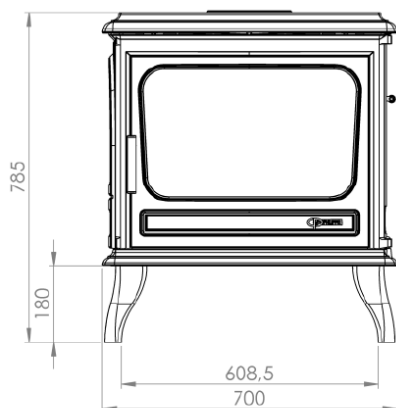

GAMME BOIS

FABRICATION FRANÇAISE



Flamme VERTE

Le label du chauffage au bois

7★

CEE Les certificats D'ÉCONOMIES D'ÉNERGIE



Caractéristiques:

- ▶ Puissance: 9kW
- ▶ Bûche 50cm
- ▶ Rendement : 76,26%
- ▶ Rendement saisonnier : 66,26%
- ▶ Co : 0,10%
- ▶ Particules : 27mg/Nm3
- ▶ Cov : 43mg/Nm3
- ▶ Nox : 80mg/Nm3
- ▶ Niveau : A
- ▶ EEI : 101
- ▶ Indice I' : 0,5
- ▶ NF EN 13240
- ▶ Poids : 187kg
- ▶ Arrivée d'air : NA
- ▶ Sortie : dessus Ø 153

Avantages:

- ▶ Corps de chauffe en fonte
- ▶ Combustion haute performance
- ▶ Fabrication Française
- ▶ Flamme verte 7*
- ▶ Ecodesign
- ▶ Double combustion

Coloris émaillé



Coloris peinture HT

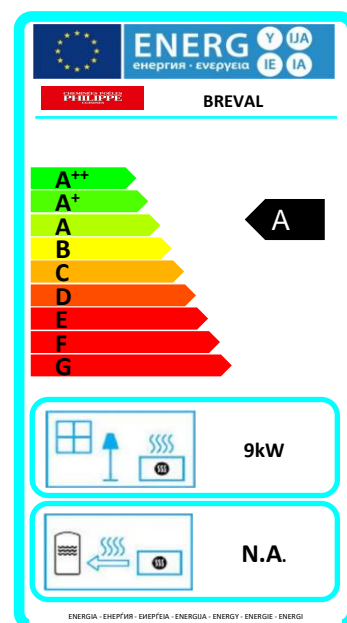

Signe votre confort depuis 1967